

Installation Instructions

Models JR3 and JR4

1. General Information (see "Selection" also): Steam Generator Location -

The steam generator should be located in a ventilated area outside of, but within 15 feet of the shower or steam room, where the steam pipes can be installed without the possibility of a steam trap. The steam generator may be placed under the floor, in a closet, or any convenient location where it WILL BE LEVEL, DRY, AND WILL NOT FREEZE in the winter. The steam generator MUST be easily accessible should service be required in the future. INSTALL THE STEAM GENERATOR WITH THE COPPER STEAM PIPES COMING OUT OF THE TOP OF THE UNIT!

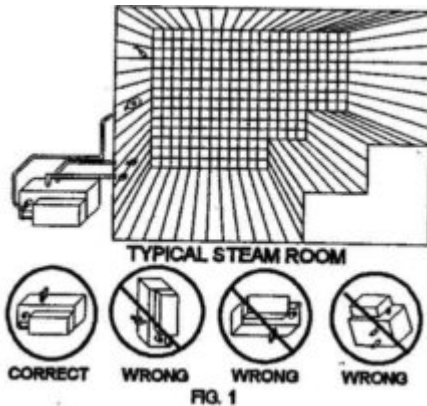

STEAM PIPES AND STEAM HEADS (To and in the steam room) The steam pipes must be a minimum of 1/2" ID rigid copper pipe between the steam generator and the area to be steamed. Installing the steam pipes by the most direct or shortest route (WITHOUT FORMING A STEAM TRAP) and by using the fewest number of elbows will, in most instances, maintain a lower pressure (less than 1 lb.) in the boiler that will a longer route with many elbows.

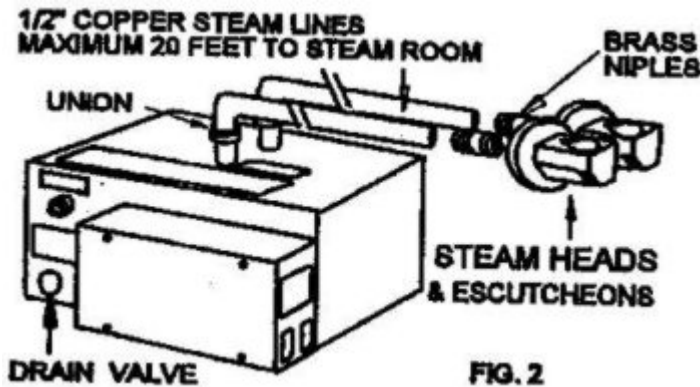

THERE IS TO BE NO RESTRICTION IN THE STEAM PIPES BETWEEN THE STEAM GENERATOR AND THE STEAM HEADS THAT WOULD ANYWAY CAUSE PRESSURE TO BUILD IN THE BOILER.

During the final installation, the steam heads supplied MUST be used. See "Steam Piping to the Steam Bath Area" and also CAUTIONS 1 and 3.

TIMER SWITCH (Steam Generator Control) The Quick Touch timer or optional programmable control switch may be located outside or inside the steam room. If using an optional timer control, refer to that control's instructions concerning installation. Relax-A-Mist timer switches are not a precise timing device. See "CAUTION #11".

Drain Valve Option (ask for details) -

A 3/4" copper, female adaptor (located under the water supply connection), can be plumbed to a drain with either a manual shut off or an automatic drain valve, installed at the steam generator (purchased separately). See fig. 2.

2. **Rough In Water Supply (according to local plumbing code) -**

The water supply pipe should be equipped with a shut-off that is accessible and close to the steam generator. Installation of a water hammer arrestor (water bumper) is recommended.

To maintain a proper water level in the generator, the water supply should have a minimum of 20 lb. pressure. If the water supply contains impurities that could build scale on or corrode the steam generator, install appropriate water treatment. See CAUTION #4 and WARRANTY POLICY.

Drain Valve Option (according to local plumbing code) -

3/4" rigid copper piping must be installed from the steam generator location to a drain. Ensure that all water is able to drain from all sections of the drain line at all times. Ask dealer for automatic drain details.

Electrical - Watts, Wire and Fuse Sizes (according to local electrical code)

LR 42682-8	JR-3	JR-4
WATTS	6000	9000
Hz	60	60
Phase	1	1
208 VOLT		
Fuse/Breaker Size	40 amp	60 amp
Copper Wire - Supply	#8 AWG	#6 AWG
Copper Wire - Switch	#22 AWG	#22 AWG
240 VOLT		
Fuse/Breaker Size	40 amp	50 amp
Copper Wire - Supply	#8 AWG	#6 AWG
Copper Wire - Switch	#22 AWG	#22 AWG

Check to ensure that the supply voltage (either 208V or 240V) is compatible with the voltage listed on the steam generator identification label. The fuses or circuit breaker must be of adequate size to carry the amperage necessary to operate the steam generator.

Select a convenient location in the steam room area, within 20 feet of the steam generator, 5 feet up from the finished floor. To install the Quick Touch Timer (found in the electrical box and cordset packaged w/ the steam unit) cut a 7/8" hole in the wall material and pass the female end of the cordset through the wall for final installation, OR, if the Programmable Control is to be used, (Purchased separately), install a double switch box. ASK A DEALER FOR DETAILS.

There is one "2 wire and ground" cable, class 1 wire, and one "2 pair stranded shielded" cable to be run to the steam generator:

- Run an electrical supply cable, 2 wire and ground of adequate gauge to carry the necessary amperage from the fuse or circuit breaker to the steam generator location.
- Run the factory supplied cordset from the steam generator location to the Quick Touch Timer location. Leave sufficient length at each end of the cordset to facilitate the final installations. SEE CAUTION 8.

THE ELECTRICAL "SUPPLY" FOR THE STEAM GENERATOR CANNOT BE SWITCHED DIRECTLY BY THE TIMER SWITCH SUPPLIED WITH THE STEAM GENERATOR.

The supply cable must be run directly to the steam generator from the fuse or circuit breaker and a separate switch cable run from the steam generator to the timer switch. The timer switch through the switch cable activates a contactor in the steam generator.

Steam Piping to Bath or Shower (1/2" rigid copper pipe required) -

Install two 1/2" rigid copper pipes (maximum 20 ft. each) from the steam generator to where they will enter the steam bath area. Install a union on the steam pipes next to the steam generator. Insulate the steam pipes for maximum efficiency.

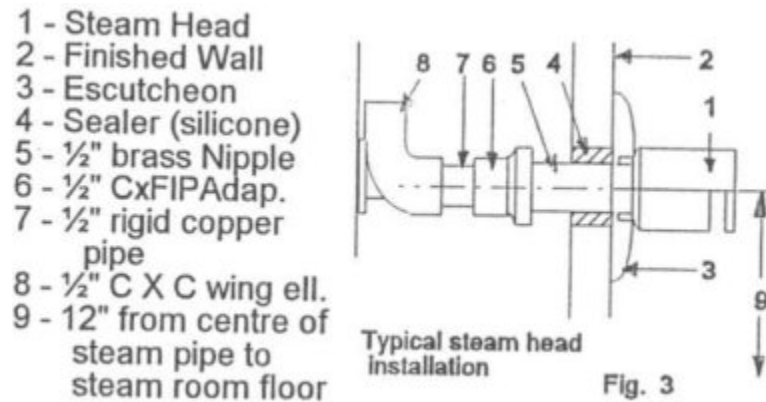

The end of the steam pipes next to the steam bath area should each have a 1/2" female pipe thread fitting that is attached to something solid, similar to the "wing back 90" elbow used to rough-in a shower head. For steam head location purposes during rough-in, install 1/2" iron pipe nipples into the two female fittings (finger tight) so they will protrude through the wall into the steam bath area. After the finished walls are in place, the iron nipples are to be replaced by brass nipples the appropriate length. See "Final Installation" "Steam Piping" and Fig. 3

In a shower or steam room the center of the brass nipples and steam heads must be 12" above the finished floor, in a position where the steam will not burn anyone, probably on the wall directly below the shower head. (see Fig. 4)

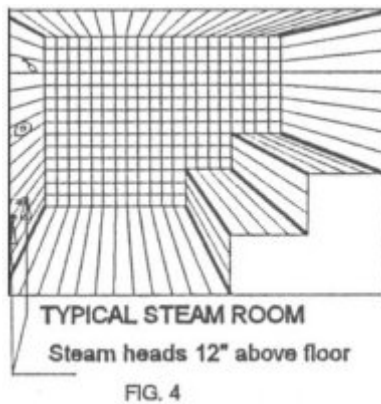

If the steam heads are installed too low, the steam will hit the floor and condense into the water before it can heat and steam the room. Also, installing the steam heads in the lower part of the room ensures a more even distribution of the steam and heat.

It is not recommended to place the steam heads under a bench, as there is a distinct possibility that someone sitting on the bench could inadvertently put their feet under it close to the steam head, and be burned. Also, when the steam heads are under a bench it is sometimes impossible for the heat and steam condensate to circulate through the room.

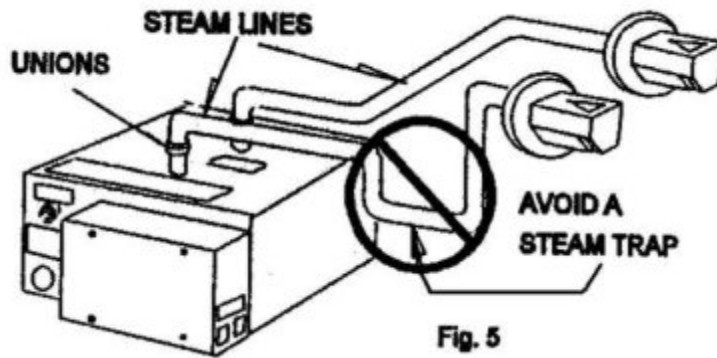

Care MUST be taken to AVOID A STEAM TRAP! Water MUST be able to drain from all sections of the steam pipes at all times. SEE CAUTIONS 1 and 2 and also Fig. 5.

3. **Final Installation: Water Supply (according to local plumbing code) -**

The water inlet connection on the steam generator is a male garden hose fitting, with a swivel garden hose to 3/8" tubing adaptor supplied. The swivel adaptor will be a union. Install a shutoff on the water supply and reduce it to use 3/8" soft copper tubing. Use 3/8" soft copper tubing between the shutoff and swivel adaptor at the steam generator. Form a loop in the 3/8" soft copper tubing to facilitate the boiler being installed level. See Fig. 6 below.

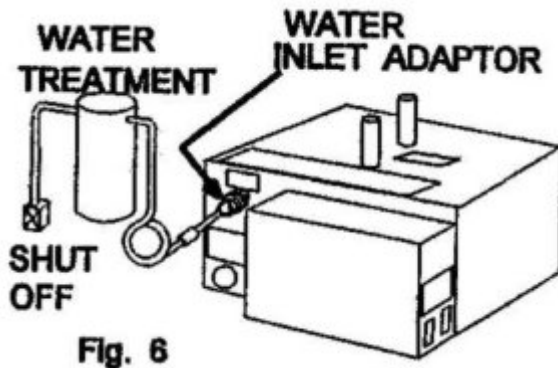

Drain Valve Option (according to local plumbing code) -

Install the shutoff (purchased separately) within 1 ft. of the steam unit, between the 3/4" copper female adaptor and a 3/4" swivel union to the drain line. For the automatic drain option, ask your dealer for details.

Electrical (according to local electrical code) -

Check to ensure that the supply voltage (either 208V or 240V) is compatible with the voltage listed on the steam generator identification label. Pull the roughed in supply cable (2 wires and ground) into the steam generator electrical connection box and proceed with "a & b" as follows; move the control cordset to the outside right of the electrical connection box and proceed with "c, d, & e" as follows:

1. Connect the ground wire to the Relax-A-Mist grounding lug.

2. Connect the two wires from the supply, one to each of the L1 and L2 Terminal. See Fig. 7

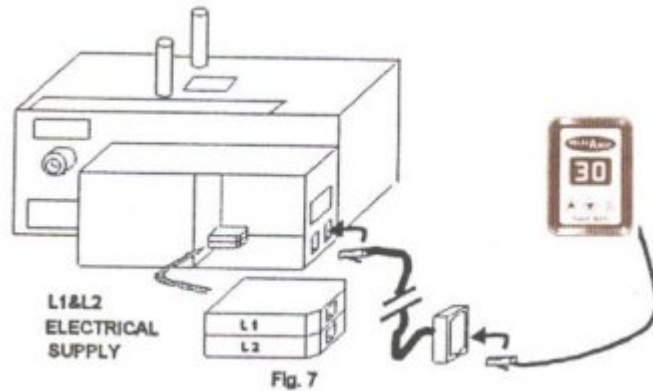

The following instructions are for the the Quick Touch Timer. If you have installed the Programmable Time and Temp. Control or an alternate, refer to their start-up instructions now and return to "STEAM PIPING".

3. At the steam generator electric box, side panel, remove the protective label marked "TIMER CONTROL" from the rear modular female plug. Front plug is for optional automatic drain. Insert the male plug of the timer cordset, retaining tab to bottom into the female plug. See electrical connections diagram page 7.
4. At the control location, remove the protective label from the female connector of the cordset. Insert the male plug of the Quick Touch Timer cord, into the female connector so the retaining tab locks in place with an audible click. See electrical connections diagram page 7.
 - Do not cut factory wiring to install time switch.
 - Do not force connections.
 - Do not adhere quick touch timer to the wall until the quick touch timer pretest is successfully completed.
 - See cautions 6, 7, 8, 9, 10 and 11.
5. Quick Touch Timer Pretest
 - With the water supply and the power supply turned on, the Quick Touch Timer display will illuminate two horizontal bars. This indicates the control is correctly connected and has power.

If display does not illuminate horizontal bars, check all electrical connections and correct it. If problem persist, call 1-800-Y-U-STEAM (1-800-987-8326) Monday to Friday 8:00am to 4:30pm Pacific Standard Time, or email steamman@relax-a-mist.com for assistance.

- When the display illuminates the horizontal bars, press the "on/off" button. The display will show 30 min. Listen to notice the Relax-A-Mist filling with water and audible click of the contactor closing. Arrow the time control down to zero. When zero is reached, the horizontal bars will appear and the Relax-A-Mist will turn off. This successfully complete the test. The Quick Touch Time may now be applied to a clean flat dry finished surface. Peel off the protective film from the back of the switch. Push the excess cord into the wall cavity. Firmly press Quick Touch Timer to wall. If surface is uneven, apply silicone sealant to outside edge, around control.
- Turn off water and power supply. Proceed with installation.

Steam Piping -

THE STEAM GENERATOR MUST BE POSITIONED WITH THE STEAM PIPE COMING OUT OF THE TOP OF THE UNIT. Using a 1/2" union, connect the roughed-in steam pipe to the generator steam pipe.

AVOID A STEAM TRAP!

Removed the 1/2 iron nipples used during the rough-in to locate the steam head positions.

Using a 1/2 brass nipples the appropriate length and escutcheons supplied, install the steam heads to hold the escutcheons tight to the wall. The steam heads must be installed with the "water droplet" on the top and the steam slot pointing down.(see Fig. 9)

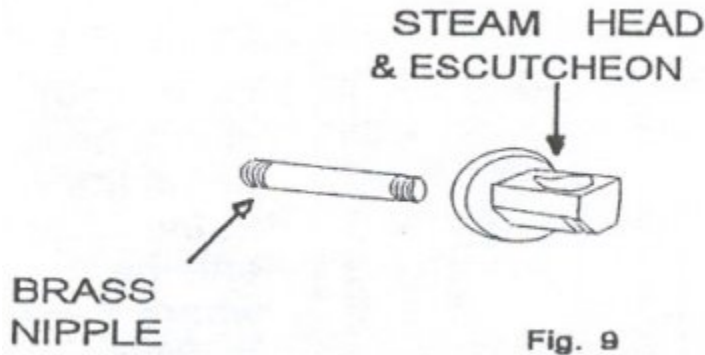

CARE MUST BE TAKEN WHEN INSTALLING THE BRASS NIPPLES TO SEAL ADEQUATELY BETWEEN THE NIPPLES AND THE WALL. WE SUGGEST FILLING THE BACK SIDE OF THE ESCUTCHEONS WITH A SEALER SUCH AS SILICONE BEFORE PRESSING IT UP TO THE WALL. (see Fig. 10)

In shower stall, where the steam line has been roughed in according to the instructions above, the installed steam head should be as close to the wall as possible and the centre of the steam head should be 12" from the finished floor.

In a bath tub area, use a chrome plated brass nipple through the wall long enough that the end of the steam head will protrude 2" past the rim of the tub, similar to the water spout, so that the steam will not come in direct contact with the bath tub rim.

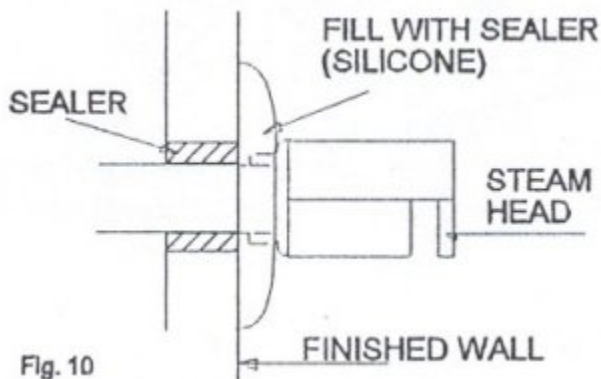

Care should be taken to seal around the nipple where it comes through the wall (a suggestion would be silicone)

CAUTION

1.
 - Under NO circumstance is the steam line from the steam generator to be restricted or reduced to less than 1/2" inside diameter, or contain a steam trap. Steam line distance maximum 20ft.
 - Under NO circumstance is there to be a valve or other obstruction in the steam line.
2. Water MUST be able to drain from ALL sections of the steam line at all times.
3. Use only the steam head that is supplied with the steam generator. For safety reasons, it MUST be used.
4. Adequately treat impure water or the warranty policy may become null and void.
5. The steam generator MUST be positioned so that THE STEAM LINE COMES OUT OF THE TOP.
6. Use only factory supplied modular connector with any unit, any substitute connector will void warranty.
7. Cutting or tampering with internal wiring will void warranty.
8. Do not pull on the plugs of the cordset during installation.
9. Check orientation of female and male low voltage connectors so as to insert parts in correct position. DO NOT FORCE CONNECTIONS.

10. Do not adhere Quick Touch Timer to wall until electrical pretest procedure has been successfully completed.
11. Installations are to be done by qualified trades people in accordance with local plumbing and electrical codes.

Steam Generator Start Up

The following instructions are for the Quick Touch Timer. If you have installed the Programmable Time & Temperature Control, or an alternate control, refer to their start up instructions now.

1. To start, make sure that the electrical supply and the water supply are both in the OFF position. Make sure that all plumbing and electrical connections are correct
2. If the drain option is used with a manual shut off, ensure it is in the closed position.
3. Turn on the water supply to the steam generator. No water will enter as the electricity is still off at this point.
4. Turn on the electrical supply to the steam generator.
5. Press the "on/off" button on the Quick Touch Timer. The display will read "30" minutes. This will energize the contactor coil which will be noticeable by an audible "click" as the contacts close and will in turn energize the water level device. The water entering the boiler will be audible in the form of short "spurts" of water, stopping when the operating water level has been reached. If unit shuts off before water fill is complete, press the "on/off" button of the Quick Touch Timer and then press the "on/off" button again to restart cycle to complete fill.
6. Approximately 2 minutes from energizing the Relax-A-Mist, steam will be entering the steam room. When the generator is first turned on, there may be an initial burst of hot water from the steam head until the steam line has come up to temperature. After the steam room has heated to satisfaction adjust the countdown time of the Quick Touch Timer by pressing the up or down arrows to increase or decrease the length of time desired for a steam bath.
7. Sit back, relax and enjoy!

Steam Generator Selection

To select the proper size of steam generator, calculate the cubic footage in the following manner:

1. Dept X width X height = CUBIC FOOTAGE. Do not deduct seating.
2. ADD TO CUBIC FOOTAGE CALCULATIONS FOR WALL AND CEILING MATERIALS, ETC:

Acrylic or Fiberglass	No Adjustment
Ceramic Tile or Cultured Marble (less than 3/8" thick)	+ 30%
EACH Glass or Glass Block Wall	+ 15%
Natural Stone (marble, onyx, slate, ceramic tile etc. 3/8" and thicker)	+ 100%
Steam Lines over 20ft. (insulate heavily)	+ 25%
Cast Iron Tub	+ 25%
Exterior Walls Subject to Freezing	+ 30%

3. Relax-A-Mist Sizing:

Model Number	JR-1	JR-2	JR-3	JR-4
Max. calculated cu. ft.	90	175	260	375

- 4.
5. Line voltage must be specified when ordering. Single family dwellings usually have 240 Volts AC while condominiums usually have 208 Volts AC.

DISCLAIMER

The above information represents suggestions only. Each steam room is unique. RELAX-A-MIST manufactures steam generators only and therefore cannot warrant information given regarding steam room materials or construction techniques.